

MM-2

APPLICATIONS & FEATURES

Powder & Bulk Processing ~ Mixing, Blending & Batching ~ Medium to High capacity Tanks & Hoppers ~ Level & Inventory Control ~ Food & Beverage Handling ~ Hostile Environment

WARRANTY

5 Year Structural Warranty

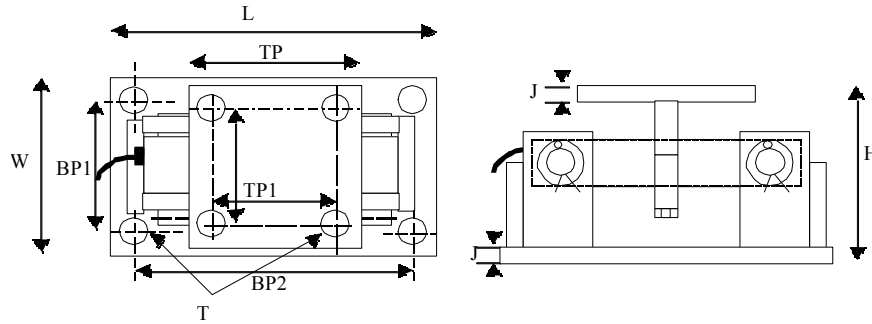

Model	Capacity	W	L	BP1	BP2	TP (Square)	TP1 (Square)	J	H	T
MM-2-5	1K, 1.5K, 2K, 2.5K, 3K, 5K	5.00	9.25	3.75	6.25	4.00	2.75	0.50	5.13	0.56
MM-2-25	10K, 15K, 20K, 25K	8.00	12.00	6.00	7.50	8.00	6.00	0.75	7.90	0.78
MM-2-75	50K, 75K	12.00	16.25	9.00	11.50	9.00	6.50	1.00	9.30	0.78

Matrix Scale Service Inc.
 301 Watline Ave. Mississauga, On L4Z 1P3
Toll Free: (800) 405-6431, Tel: (905) 712-8987 Fax: (905) 712-4947
www.matrixscale.com