

MM-7

APPLICATIONS & FEATURES

Axle Scales ~ Truck Scales ~ Railroad Scales ~ Heavy capacity Tanks & Hoppers ~ Livestock Scales

WARRANTY

5 Year Structural Warranty

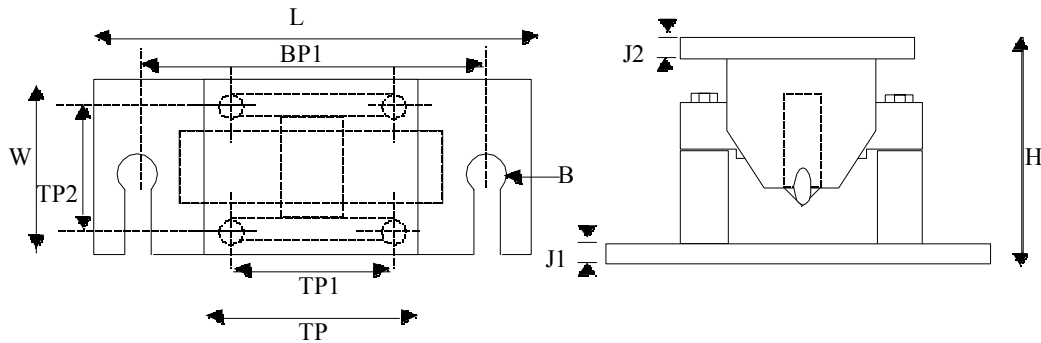
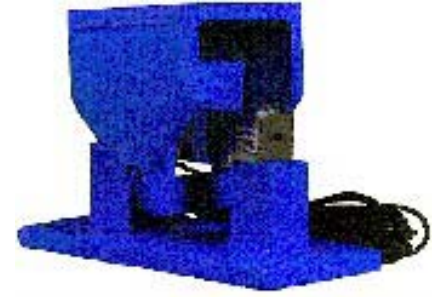

Model	Capacity	W	L	TP	TP1	TP2	J1	J2	B (DIA)	H
MM-7-25	10K, 20K, 25k	6.00	14.00	6.00	3.00	3.00	0.62	0.62	1.75	8.75
MM-7-75	50K, 60K, 75k	7.00	18.00	12.75	5.00	3.50	0.75	0.75	2.00	11.00

Matrix Scale Service Inc.
301 Watline Ave. Mississauga, On L4Z 1P3
Toll Free: (800) 405-6431, Tel: (905) 712-8987 Fax: (905) 712-4947
www.matrixscale.com